

ASSEMBLY

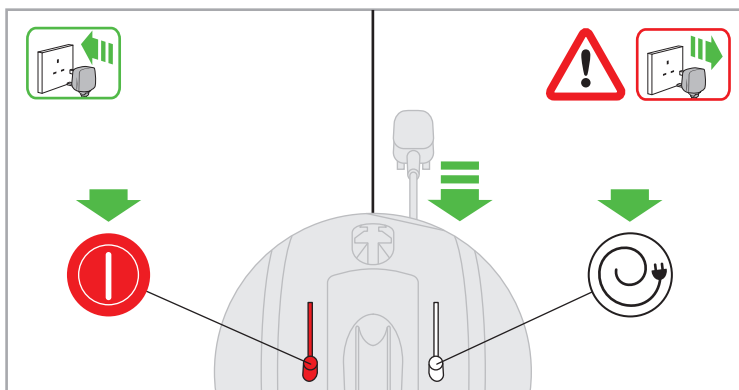

1 month
WASH FILTERS
Wash filters with cold water at least every month.

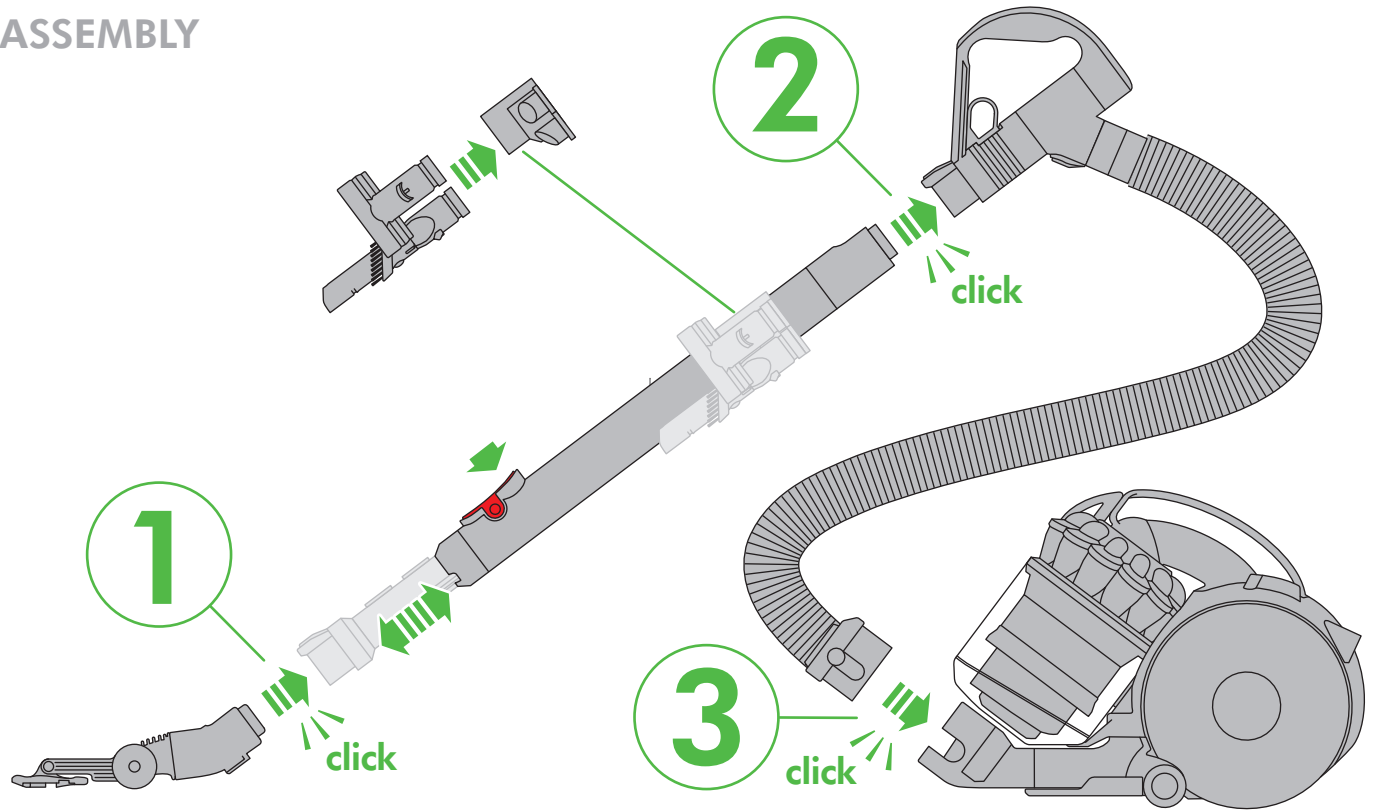
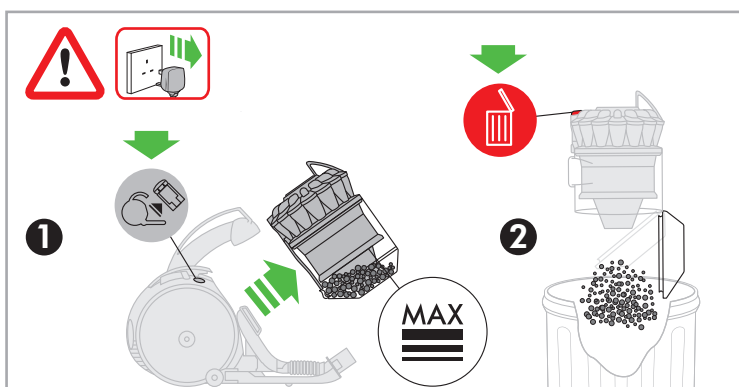

**REGISTER
YOUR FREE
5 YEAR
GUARANTEE
TODAY**

DYSON CUSTOMER CARE

THANK YOU FOR CHOOSING TO BUY A DYSON APPLIANCE

After registering your free 5 year guarantee, your Dyson appliance will be covered for parts and labour for 5 years from the date of purchase, subject to the terms of the guarantee.

If you have any questions about your Dyson appliance, call the Dyson Helpline with your serial number and details of where/when you bought the appliance.

Most questions can be solved over the phone by one of our trained Dyson Helpline staff.

Alternatively, visit www.dyson.co.uk/support for online help, general tips and useful information about Dyson.

Note your serial number for future reference

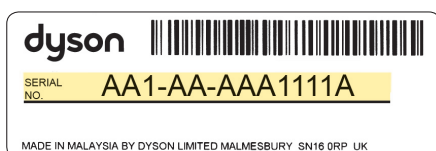

This illustration is for example purposes only.

DYSON CONTACT DETAILS

Website: www.dyson.com/support

UK:

Dyson Helpline: 0800 298 0298

Open 7am–10pm. 7 days a week.

Email: askdyson@dyson.co.uk

Address: Dyson Limited, Tetbury Hill, Malmesbury, Wiltshire
SN16 ORP England.

ROI:

Dyson Helpline: 01 475 7109

Open 7am–10pm. 7 days a week.

Email: askdyson@dyson.com

Address: Unit 10, Grants Lane, Greenogue Business Park,
Rathcoole, Dublin 24.

IMPORTANT SAFETY INSTRUCTIONS

BEFORE USING THIS APPLIANCE READ ALL INSTRUCTIONS AND CAUTIONARY MARKINGS IN THIS MANUAL AND ON THE APPLIANCE

When using an electrical appliance, basic precautions should always be followed, including the following:

WARNING

TO REDUCE THE RISK OF FIRE, ELECTRIC SHOCK, OR INJURY:

1. This Dyson appliance is not intended for use by young children or infirm persons with reduced physical, sensory or reasoning capabilities, or lack of experience and knowledge, unless they have been given supervision or instruction by a responsible person concerning use of the appliance to ensure that they can use it safely.
2. Do not allow to be used as a toy. Close attention is necessary when used by or near children. Children should be supervised to ensure that they do not play with the appliance.
3. Use only as described in this Dyson Operating Manual. Do not carry out any maintenance other than that shown in this manual, or advised by the Dyson Helpline.
4. Suitable for dry locations only. Do not use outdoors or on wet surfaces.
5. Do not handle any part of the plug or appliance with wet hands.
6. Do not use with a damaged cable or plug. If the supply cable is damaged it must be replaced by Dyson, its service agent or similarly qualified person in order to avoid a hazard.
7. If the appliance is not working as it should, has received a sharp blow, has been dropped, damaged, left outdoors, or dropped into water, do not use and contact the Dyson Helpline.
8. Contact the Dyson Helpline when service or repair is required. Do not disassemble the appliance as incorrect reassembly may result in an electric shock or fire.
9. Do not stretch the cable or place the cable under strain. Keep the cable away from heated surfaces. Do not close a door on the cable, or pull the cable around sharp edges or corners. Arrange the cable away from traffic areas and where it will not be stepped on or tripped over. Do not run the appliance over the cable.
10. Do not unplug by pulling on the cable. To unplug, grasp the plug, not the cable. The use of an extension cable is not recommended.
11. Do not use to pick up water.
12. Do not use to pick up flammable or combustible liquids, such as petrol, or use in areas where they or their vapours may be present.
13. Do not pick up anything that is burning or smoking, such as cigarettes, matches, or hot ashes.
14. Keep hair, loose clothing, fingers, and all parts of the body away from openings and moving parts. Do not point the hose, wand or tools at your eyes or ears or put them in your mouth.
15. Do not put any object into openings. Do not use with any opening blocked; keep free of dust, lint, hair, and anything that may reduce airflow.
16. Use only Dyson recommended accessories and replacement parts.
17. To avoid a tripping hazard rewind the cable when not in use.
18. Do not use without the clear bin and filters in place.
19. Do not leave the appliance when plugged in. Unplug when not in use and before servicing.
20. Do not pull or carry by cable or use cable as a handle.
21. Use extra care when cleaning on stairs. Do not work with the appliance above you on the stairs.
22. Turn off all controls before unplugging. Unplug before connecting any tool or accessory.
23. Always extend the cable to the red line but do not stretch or tug the cable.
24. Hold the plug when rewinding onto cable reel. Do not allow the plug to whip when rewinding.

READ AND SAVE THESE INSTRUCTIONS

THIS DYSON APPLIANCE IS INTENDED FOR HOUSEHOLD USE ONLY

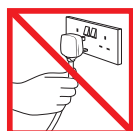

Do not pull on the cable.

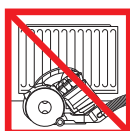

Do not store near heat sources.



Do not use near naked flames.



Do not run over the cable.



Do not pick up water or liquids.



Do not pick up burning objects.



Do not use above you on the stairs.

Power & cable

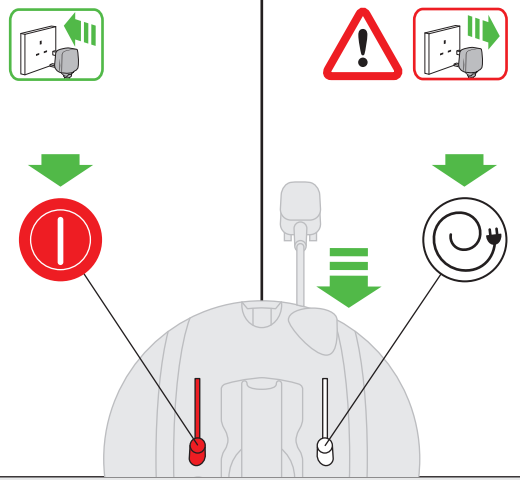

Tool attachments

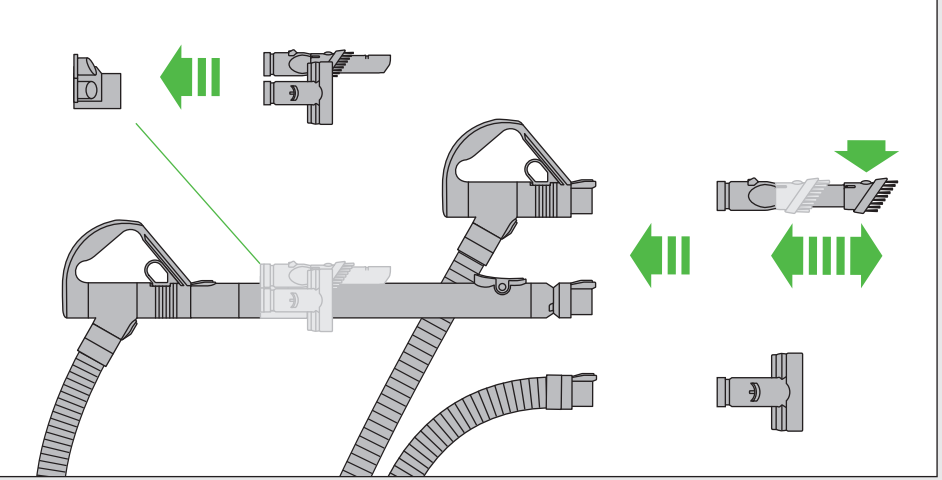

Emptying

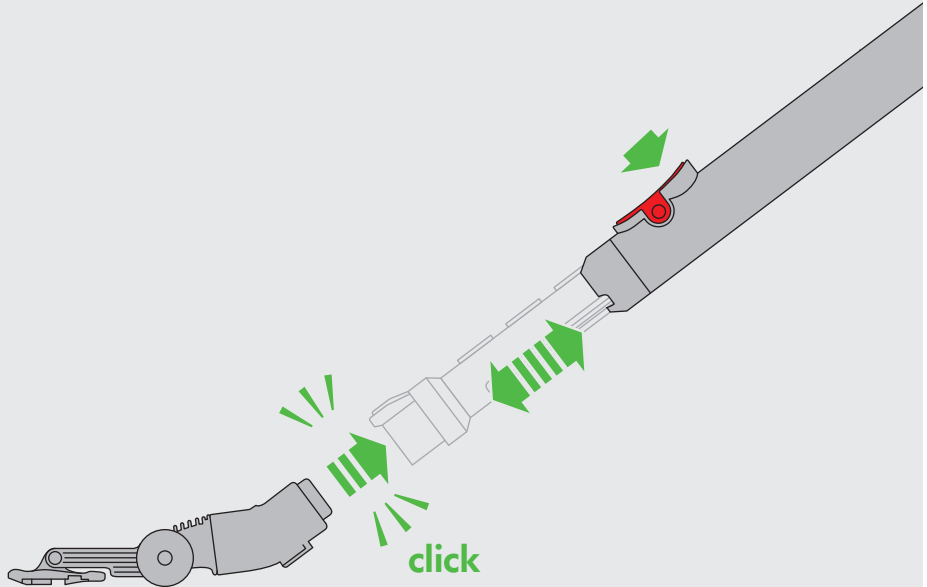
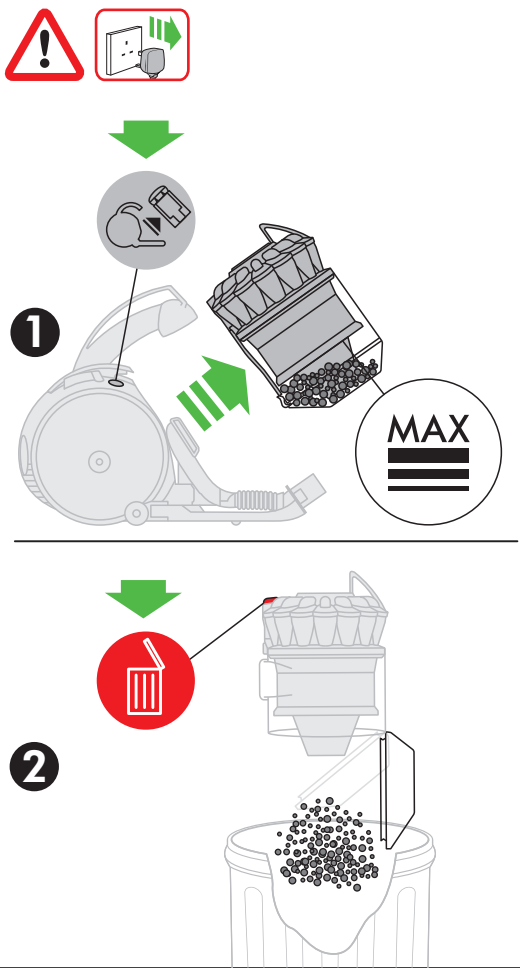

Looking for blockages

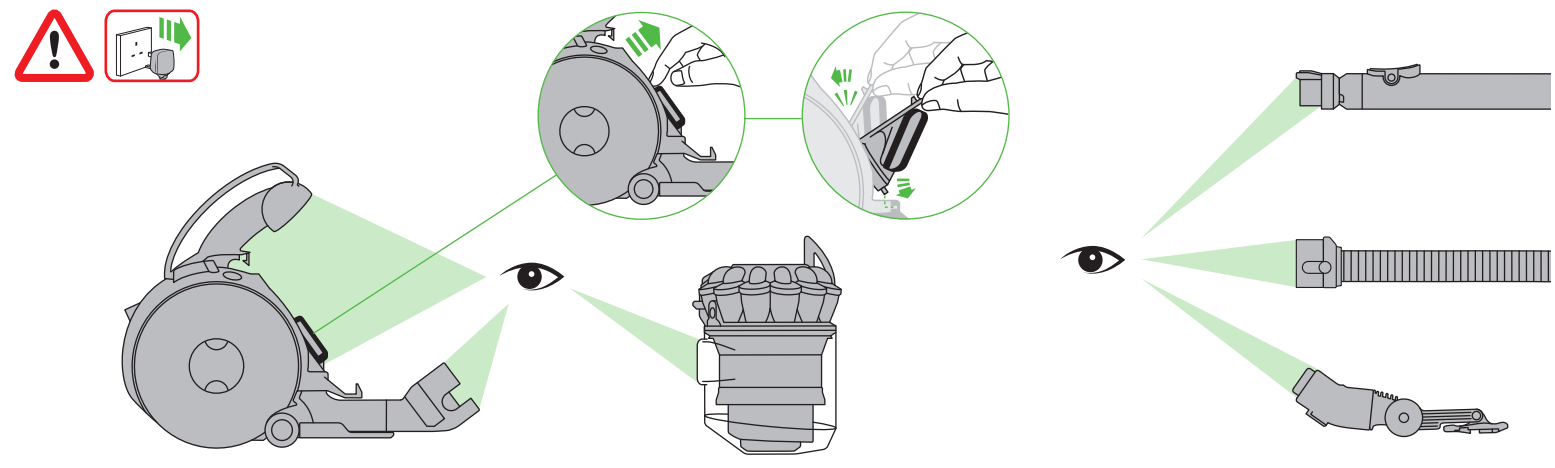

Suction release

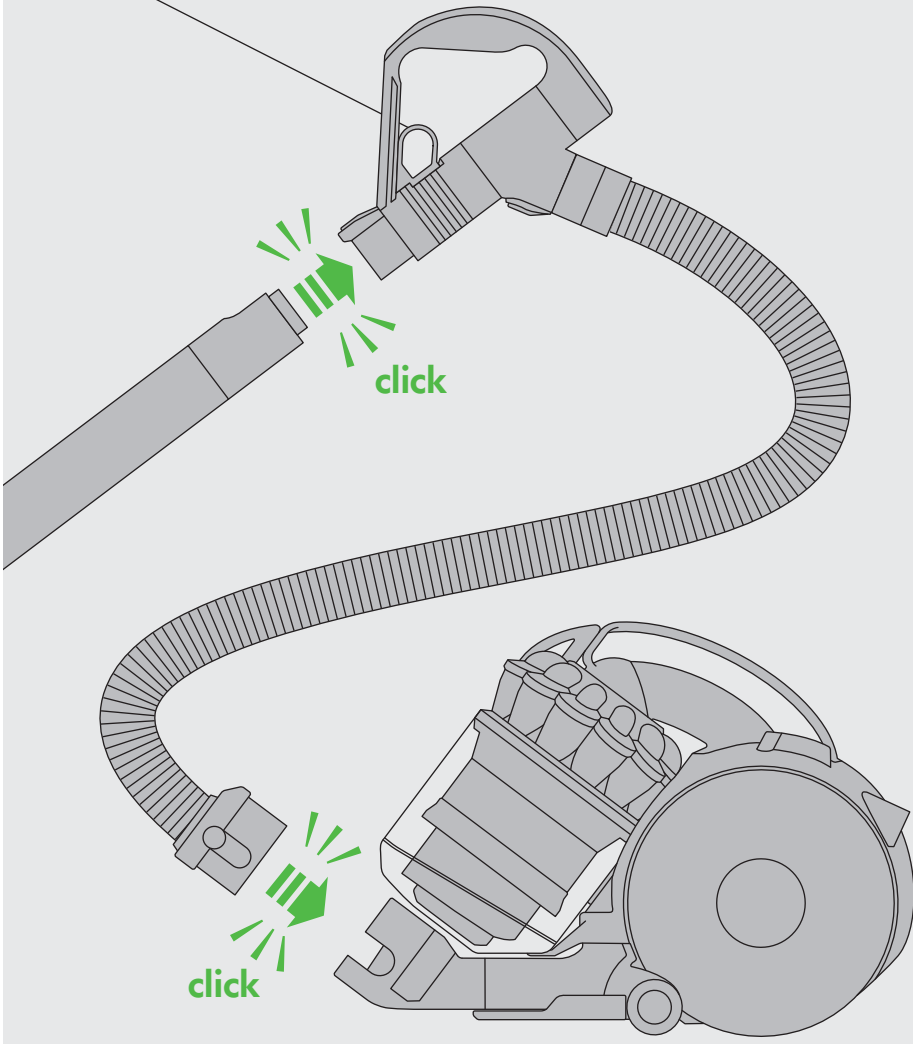
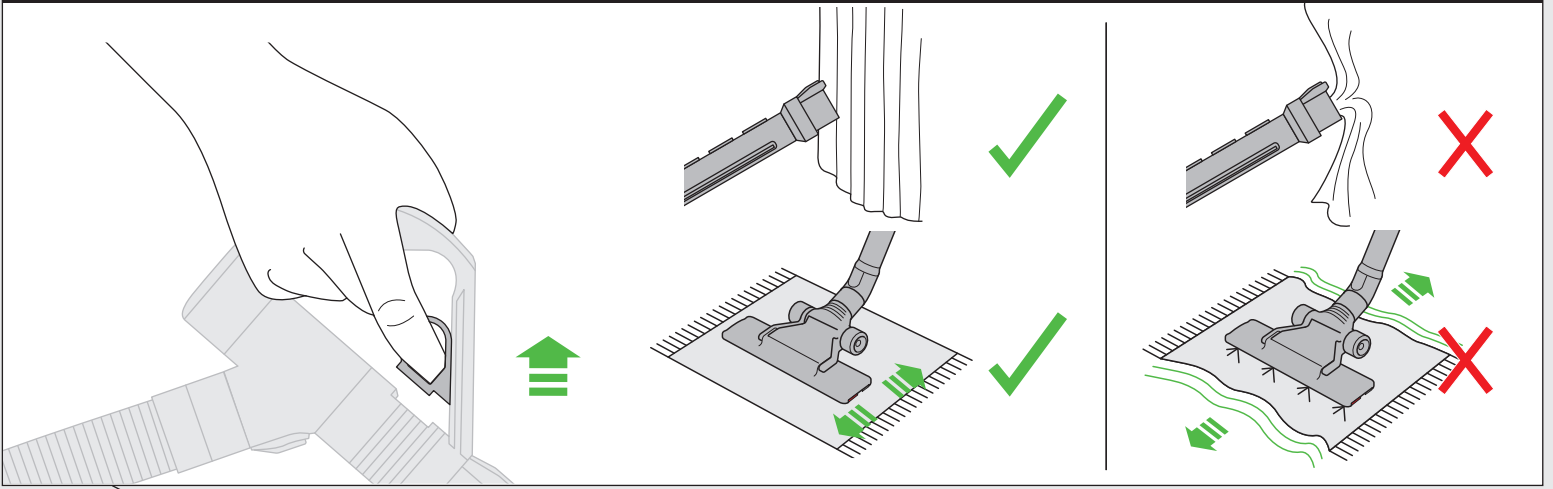

Carrying & storage

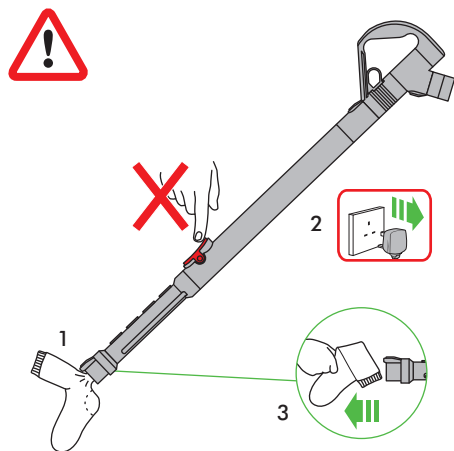
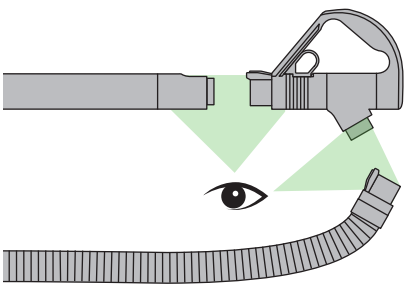
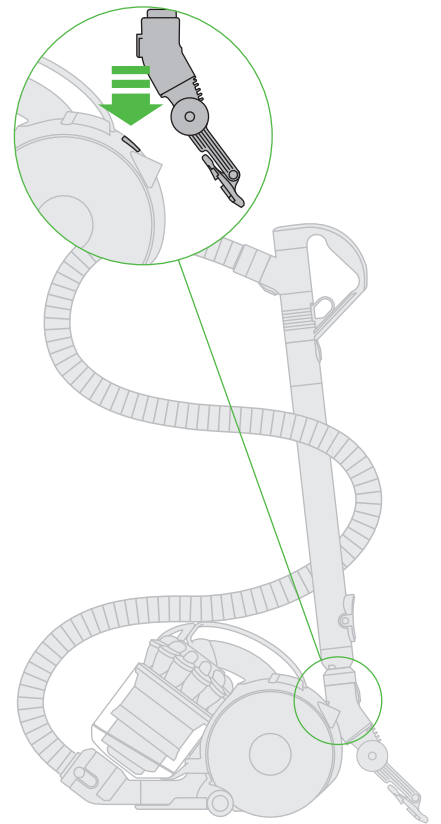
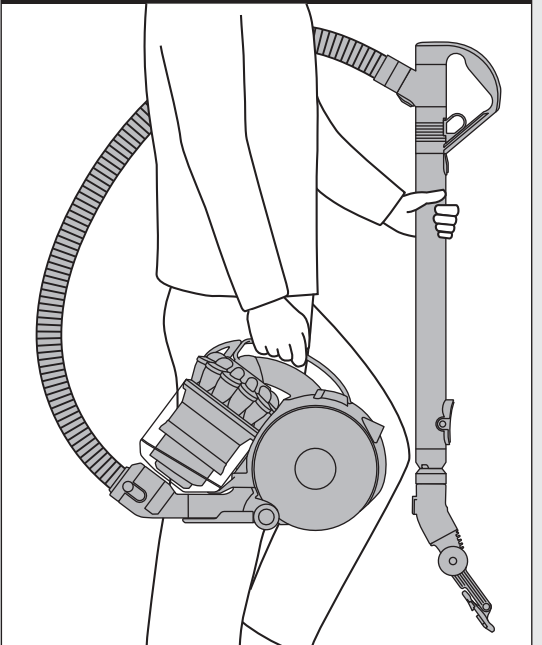

IMPORTANT!

WASH FILTERS

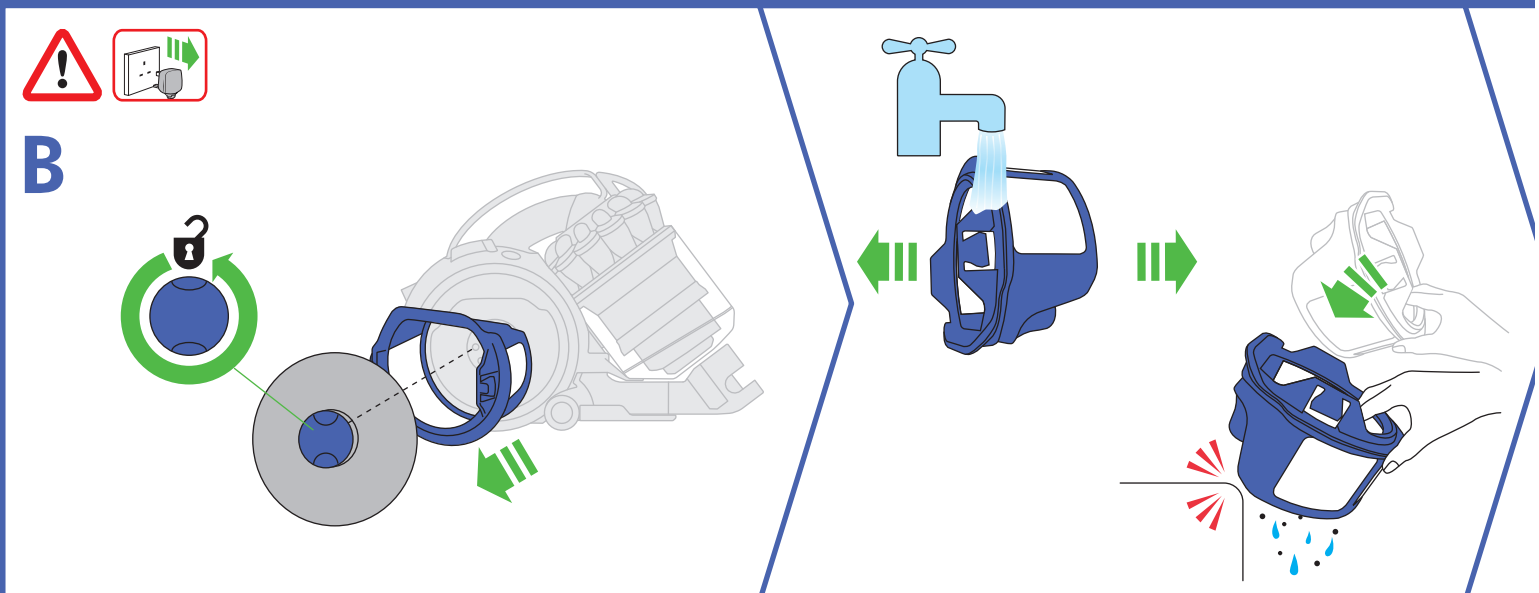
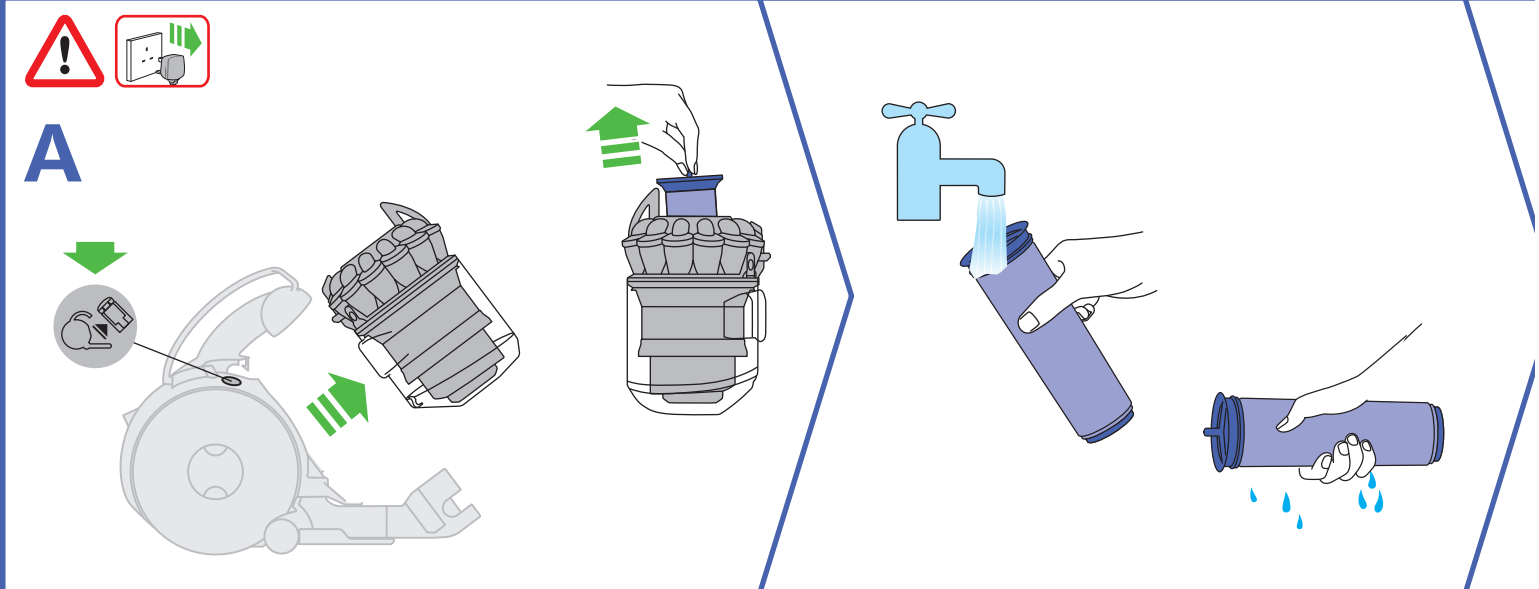

Cleaning

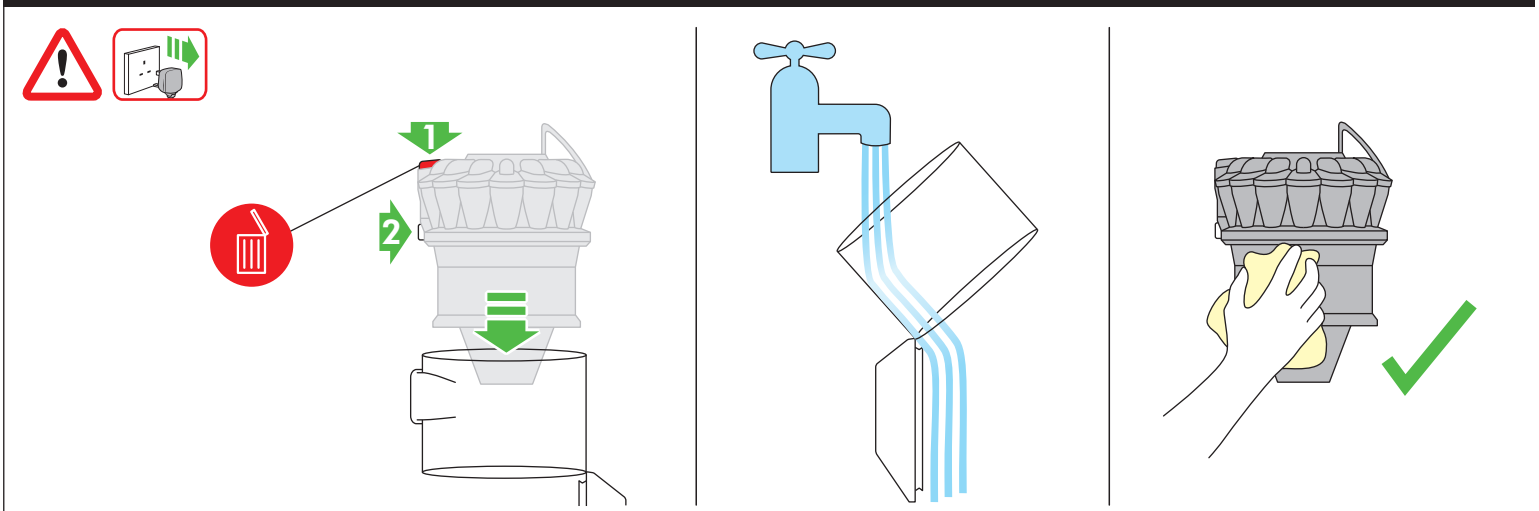

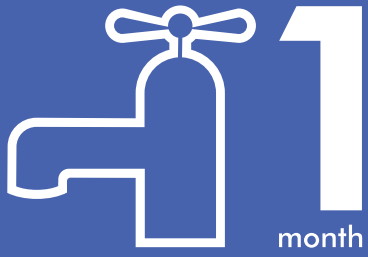

Wash filters with cold water at least every month.

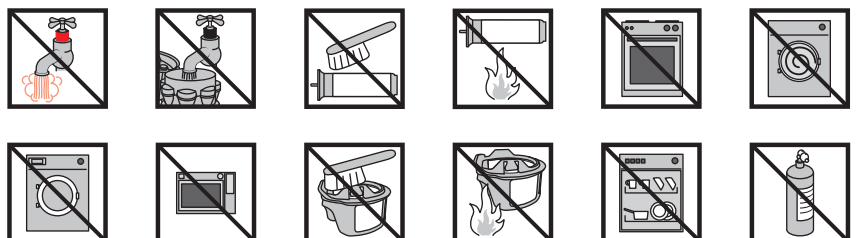
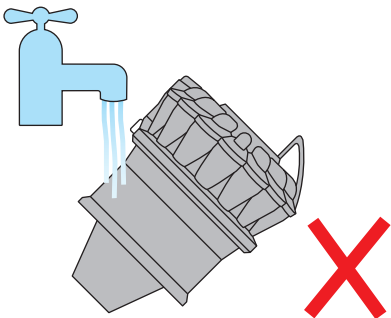
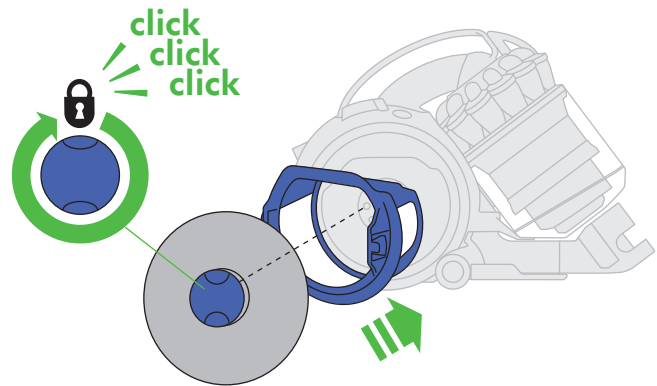
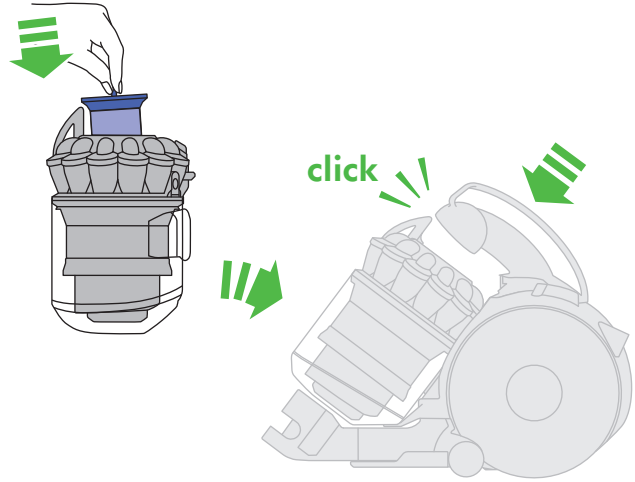
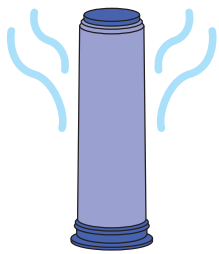

USING YOUR DYSON APPLIANCE

PLEASE READ THE 'IMPORTANT SAFETY INSTRUCTIONS' IN THIS DYSON OPERATING MANUAL BEFORE PROCEEDING.

CARRYING THE APPLIANCE

- Carry the appliance by the main handle on the body.
- Do not press the cyclone release button or shake the appliance when carrying, or the cyclone could disengage, fall off and cause injury.

OPERATION

- Always extend the cable fully to the red tape before use.
- Plug the appliance into the mains electricity supply.
- To switch 'ON' or 'OFF' press the power button, located as shown.
- After use: unplug, retract the cable safely, put the appliance away.
- Switch 'OFF' the appliance and unplug before:
 - changing or using tools
 - removing the hose or airway inspection parts.
- To watch a short online video visit:
UK – www.dyson.co.uk/DC38gettingstarted
ROI – www.dyson.ie/DC38gettingstarted

LOOKING AFTER YOUR DYSON APPLIANCE

- Do not carry out any maintenance or repair work other than that shown in this Dyson Operating Manual, or advised by the Dyson Helpline.
- Only use parts recommended by Dyson. If you do not this could invalidate your guarantee.
- Store the appliance indoors. Do not use or store it below 0°C (32°F). Ensure the appliance is at room temperature before operating.
- Clean the appliance only with a dry cloth. Do not use any lubricants, cleaning agents, polishes or air fresheners on any part of the appliance.
- If used in a garage, always wipe the base plate and ball with a dry cloth after vacuuming to clean off any sand, dirt, or pebbles that could damage delicate floors.

VACUUMING - CAUTION

- Do not use without the clear bin and filters in place.
- Fine dust such as plaster dust or flour should only be vacuumed in very small amounts.
- Do not use the appliance to pick up sharp hard objects, small toys, pins, paper clips, etc. They may damage the appliance.
- When vacuuming, certain carpets may generate small static charges in the clear bin or wand. These are harmless and are not associated with the mains electricity supply. To minimise any effect from this, do not put your hand or insert any object into the clear bin unless you have first emptied it and rinsed it out with cold water (see 'Cleaning the clear bin').
- Powerful suction can cause the hose to 'pull back' – please take care.
- Do not work with the appliance above you on the stairs.
- Do not put the appliance on chairs, tables, etc.
- Before vacuuming highly polished floors, such as wood or lino, first check that the underside of the floor tool is free from foreign objects that could cause marking.
- Do not push hard with the floor tool when vacuuming, as this may cause damage.
- Do not leave the cleaner head in one place on delicate floors.
- On waxed floors the movement of the cleaner head may create an uneven lustre. If this happens, wipe with a damp cloth, polish the area with wax, and wait for it to dry.

EMPTYING THE CLEAR BIN

- Empty as soon as the dirt reaches the level of the MAX mark – do not overfill.
- Switch 'OFF' and unplug before emptying the clear bin.
- To remove the cyclone and clear bin unit, push the release button to the side of the carrying handle, as shown. The carrying handle will be released.
- Remove the cyclone and clear bin unit.
- To release the dirt, press the red bin release button.
- To minimise dust/allergen contact when emptying, encase the clear bin tightly in a plastic bag and empty.
- Remove the clear bin carefully.
- Seal the bag tightly, dispose as normal.
- Close the clear bin base so it clicks into place and is secure.
- Place the clear bin and cyclone unit into position on the front of the main body of the appliance. The recess in the base of the clear bin must fit onto the lug on the locator bracket.
- Push the carrying handle down so it clicks into place on the top of the clear bin and cyclone unit. Ensure it is secure.

CLEANING THE CLEAR BIN

- Remove the cyclone and clear bin unit, and then open the bin base (instructions above).
- To separate the cyclone unit from the clear bin press the small silver button on the cyclone. Separate the cyclone from the clear bin.
- Clean the clear bin with cold water only.
- Do not use detergents, polishes or air fresheners to clean the clear bin.
- Do not put clear bin in a dishwasher.
- Do not immerse the whole cyclone in water or pour water into it.
- Clean the cyclone shroud with a dry cloth or dry brush to remove lint and dust.
- Ensure the clear bin is completely dry before replacing.
- To replace, first close the clear bin base so it clicks into place and is secure.
- Fit the clear bin onto the cyclone. To secure it, first fit the slot on the front rim of the clear bin onto the lug on the front of the cyclone; then push the rear of the clear bin into place so the silver button engages and clicks into place.
- Fit the cyclone and clear bin unit onto the appliance (instructions above).

WASHING THE FILTERS

- Your appliance has two washable filters, located as shown.
- Check and wash the filters regularly according to instructions to maintain performance.
- Switch 'OFF' and unplug before checking or removing the filters.
- The filters may require more frequent washing if vacuuming fine dust.
- Wash the filters with cold water only. Do not use detergents.
- Do not put the filters in a dishwasher, washing machine, tumble dryer, oven, microwave or near a naked flame.

Filter A

- To access filter A, first remove the clear bin and cyclone unit (instructions above). Lift out the filter.
- Wash the filter with cold water only. Hold under a tap and run water through the open end for 10 seconds. Turn upside down and tap out 10 times.
- Squeeze and twist with both hands to make sure the excess water is removed.
- Run water over the outside of the filter for 15 seconds.
- Squeeze and twist with both hands to make sure the excess water is removed.
- Stand the filter on its wide, open end to dry. Leave to dry completely for 24 hours.
- Replace the filter into the cyclone. Fit the cyclone and clear bin unit onto the appliance (instructions above).

Filter B

- To remove filter B:
 - turn the central locking dial on the outer cover of the ball anti-clockwise until the cover is released
 - lift off the cover
 - turn the filter one-quarter anti-clockwise to release.
- Filter B should be rinsed in cold water only and tapped out until the water runs clean, then tapped out again to ensure all excess water is removed. (Tap on the plastic rim, not the filter material.)
- Leave to dry completely for 24 hours.
- It is normal for the filter in the ball to turn grey in colour.
- To refit filter B:
 - refit the filter on to the ball
 - secure the filter by turning it one-quarter turn clockwise.
- When refitting the outer cover of the ball, keep turning the central locking dial clockwise. When it starts to click it is locked.
- To watch a short online video visit:
UK – www.dyson.co.uk/DC38filterwash
ROI – www.dyson.ie/DC38filterwash

LOOKING FOR BLOCKAGES

- Switch 'OFF' and unplug before looking for blockages. Failure to do so could result in personal injury.
- Beware of sharp objects when checking for blockages.
- Refit all parts securely before using.
- To check for blockages in airway on the main body of the appliance, first remove the cyclone and clear bin unit (see above).
- To remove the transparent inlet section, use your finger to release the latch on the top. Remove the inlet section.
- Inspect for blockages.
- Replace the inlet section. Ensure the latch clicks into place and engages.
- Clearing blockages is not covered by your guarantee.

CLEARING BLOCKAGES – THERMAL CUT-OUT

- This appliance is fitted with an automatically resetting thermal cut-out.
- Large items may block the tools or wand inlet. If any part becomes blocked the appliance may overheat and automatically cut-out.
- Switch 'OFF' and unplug. Leave to cool down for 1-2 hours before checking filters or for blockages. Do not operate the wand release catch.
- Clear any blockage before restarting.

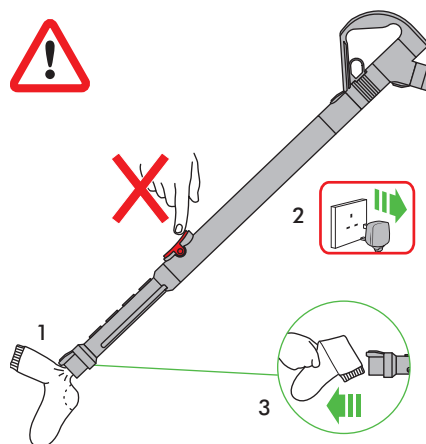

DISPOSAL INFORMATION

Dyson products are made from high grade recyclable materials. Please dispose of this product responsibly and recycle where possible.

GUARANTEE TERMS & CONDITIONS

DYSON CUSTOMER CARE

THANK YOU FOR CHOOSING TO BUY A DYSON APPLIANCE

After registering your free 5 year guarantee, your Dyson appliance will be covered for parts and labour for 5 years from the date of purchase, subject to the terms of the guarantee.

If you have any questions about your Dyson appliance, call the Dyson Helpline with your serial number and details of where/when you bought the appliance. Most questions can be solved over the phone by one of our trained Dyson Helpline staff.

Alternatively, visit www.dyson.co.uk/support for online help, general tips and useful information about Dyson.

If your Dyson appliance needs a service, call the Dyson Helpline so we can discuss the available options. If your Dyson appliance is under guarantee, and the repair is covered, it will be repaired at no cost.

Your serial number can be found on your rating plate which is on the base of the appliance.

PLEASE REGISTER AS A DYSON APPLIANCE OWNER

To help us ensure you receive prompt and efficient service, please register as a Dyson appliance owner. There are three ways to do this:

- Online at www.dyson.co.uk/register (UK) or www.dyson.ie/support (ROI).
 - Telephone the Dyson Helpline.
 - Mail Complete the enclosed form and post it to us.
- This will confirm ownership of your Dyson appliance in the event of an insurance loss, and enable us to contact you if necessary.

LIMITED 5 YEAR GUARANTEE

TERMS AND CONDITIONS OF THE DYSON 5 YEAR LIMITED GUARANTEE.

WHAT IS COVERED

- The repair or replacement of your Dyson appliance (at Dyson's discretion) if it is found to be defective due to faulty materials, workmanship or function within 5 years of purchase or delivery (if any part is no longer available or out of manufacture Dyson will replace it with a functional replacement part).
- Use of the Dyson appliance in country of purchase only.

WHAT IS NOT COVERED

Dyson does not guarantee the repair or replacement of a product where a defect is the result of:

- Accidental damage.
- Faults caused by negligent use or care, misuse, neglect, careless operation or handling of the appliance which is not in accordance with the Dyson Operating Manual.
- Use of the appliance for anything other than normal domestic household purposes.
- Use of parts not assembled or installed in accordance with the instructions of Dyson.
- Use of parts and accessories which are not genuine Dyson components.
- Faulty installation (except where installed by Dyson).
- Repairs or alterations carried out by parties other than Dyson or its authorised agents.
- Blockages – please refer to the Dyson Operating Manual for details of how to look for and clear blockages.
- Normal wear and tear (e.g. fuse, etc).

If you are in any doubt as to what is covered by your guarantee, please contact Dyson.

SUMMARY OF COVER

- The guarantee becomes effective at the date of purchase (or the date of delivery if this is later).
- You must provide proof of (both the original and any subsequent) delivery/purchase before any work can be carried out on your Dyson appliance. Without this proof, any work carried out will be chargeable. Keep your receipt or delivery note.
- All work will be carried out by Dyson or its authorised agents.
- Any parts which are replaced will become the property of Dyson.
- The repair or replacement of your Dyson appliance under guarantee will not extend the period of guarantee.
- The guarantee provides benefits which are additional to and do not affect your statutory rights as a consumer.

ABOUT YOUR PRIVACY

- Your information will be held by Dyson Limited and its agents for promotional, marketing and servicing purposes.
- If your personal details change, if you change your mind about any of your marketing preferences or if you have any queries about how we use your information, please contact Dyson Limited.
- For more information on how we protect your privacy, please see our privacy policy on the Dyson website.

IMPORTANT!

WASH FILTERS

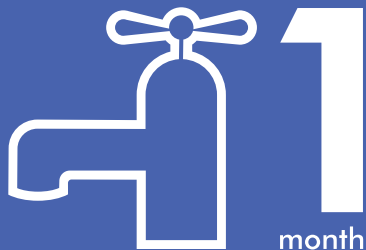

Wash filters with cold water at least every month.
The filters may require more frequent washing if vacuuming fine dust.



Dyson Customer Care

Dyson Customer Care

After registering your free 5 year guarantee, your Dyson appliance will be covered for parts and labour for 5 years from the date of purchase, subject to the terms of the guarantee.

If you have any questions about your Dyson appliance, call the Dyson Helpline with your serial number and details of where/when you bought the appliance.

Most questions can be solved over the phone by one of our trained Dyson Helpline staff.

UK Dyson Customer Care
askdyson@dyson.co.uk
0800 298 0298

Dyson Ltd, Tetbury Hill, Malmesbury, Wiltshire SN16 0RP.

ROI Dyson Customer Care
irelandservice@dyson.com
01 475 7109

Dyson Ireland Limited, Unit G10, Grants Lane,
Greenogue Business Park, Rathcoole, Dublin 24.





GUARANTEE FORM

Serial number

Date of purchase / / Country of purchase UK ROI

Title Surname

First name

Address

Postcode

email

Telephone Mobile

As a Dyson vacuum cleaner owner, you can hear about Dyson inventions, services and products before anyone else. If it's okay to contact you, please let us know how we may do this.

We sometimes ask other companies (such as market researchers) to contact owners on our behalf. We do this to get feedback on ideas or ask you to try new products and services. Would this be okay?

By mail Yes No
By phone Yes No
By email Yes No
By text message Yes No

Yes No

3 EASY WAYS TO REGISTER FOR YOUR FREE 5 YEAR GUARANTEE



REGISTER ONLINE

Visit our website to register your full parts and labour guarantee online.

www.dyson.com/register



REGISTER BY PHONE

Call our dedicated Helpline. Open 7am-10pm. 7 days a week.

UK 0800 298 0298
ROI 01 475 7109



REGISTER BY MAIL

Complete and return the form to Dyson in the envelope supplied.

