

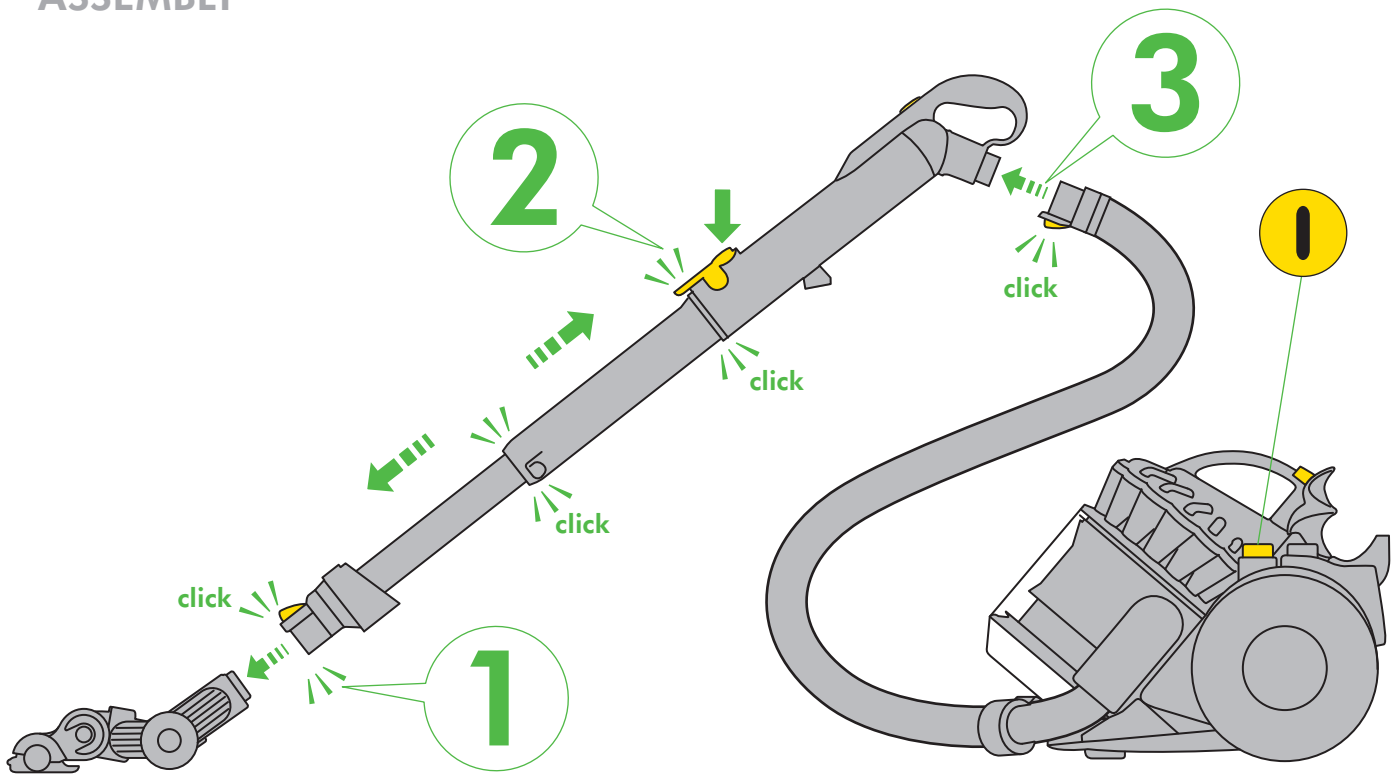

ASSEMBLY

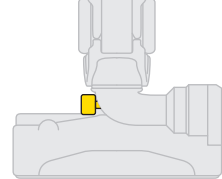

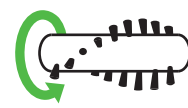

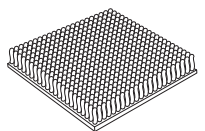
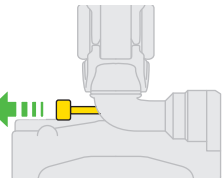

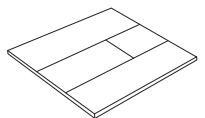
 **1** month
WASH FILTERS
Wash filters with cold water at least every month.

A **B**

REGISTER FOR YOUR FREE 5 YEAR GUARANTEE TODAY

	
--	---

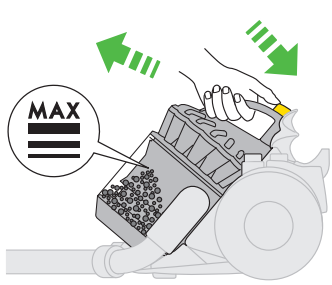
After registering for your 5 year guarantee, your Dyson vacuum cleaner will be covered for parts and labour for 5 years from the date of purchase, subject to the terms of the guarantee.

If you have any query about your Dyson vacuum cleaner, call the Dyson Customer Care Helpline with your serial number and details of where/when you bought the vacuum cleaner. Your serial number can be found on your rating plate which is behind the clear bin.

Most queries can be solved over the phone by one of our trained Dyson Customer Care Helpline staff.

Alternatively visit www.dyson.co.uk/support for online help, general tips and useful information about Dyson.

Note your serial number for future reference



3 EASY WAYS TO REGISTER FOR YOUR FREE 5 YEAR GUARANTEE

REGISTER ONLINE

Visit our website to register your full parts and labour guarantee online.

www.dyson.com/register



REGISTER BY PHONE

Call our dedicated Helpline
Open 7am–10pm.
7 days a week.

UK 0800 298 0298
IRL 01 475 7109



REGISTER BY MAIL

Complete and return the form to Dyson in the envelope supplied.



IMPORTANT SAFETY INSTRUCTIONS

READ ALL INSTRUCTIONS BEFORE USING THIS APPLIANCE

When using an electrical appliance, basic precautions should always be followed, including the following:

WARNING

TO REDUCE THE RISK OF FIRE, ELECTRIC SHOCK, OR INJURY:

1. Do not leave the Dyson vacuum when plugged in. Unplug from socket when not in use and before servicing.
2. Do not use outdoors or on wet surfaces. Suitable for dry locations only. Do not use to pick up water.
3. Do not allow to be used as a toy. Close attention is necessary when used by or near children. Children should be supervised to ensure that they do not play with the Dyson vacuum.
4. This Dyson vacuum is not intended for use by young children or infirm persons with reduced physical, sensory or reasoning capabilities, or lack of experience and knowledge, unless they have been given supervision or instruction by a responsible person concerning use of the Dyson vacuum to ensure that they can use the Dyson vacuum safely.
5. Use only as described in this manual. Use only Dyson recommended accessories and replacement parts. Do not carry out any maintenance other than that shown in this manual, or advised by the Dyson Customer Care Helpline. Contact the Dyson Customer Care Helpline when service or repair is required. Do not disassemble the Dyson vacuum as incorrect reassembly may result in an electric shock or fire.
6. Do not use with a damaged cable or plug. If the Dyson vacuum is not working as it should, has been dropped, damaged, left outdoors, or dropped into water, do not use and contact the Dyson Customer Care Helpline. If the supply cable is damaged it must be replaced by Dyson, its service agent or similarly qualified person in order to avoid a hazard.
7. Do not pull or carry by cable, use cable as a handle, close a door on cable, or pull cable around sharp edges or corners. Do not run the Dyson vacuum over cable. Keep cable away from heated surfaces. To avoid a tripping hazard rewind the cable when not in use.
8. Always extend the cable to the red line but do not stretch or tug the cable.
9. Do not unplug by pulling on the cable. To unplug, grasp the plug, not the cable.
10. Do not handle the plug or Dyson vacuum with wet hands.
11. Do not put any object into openings. Do not use with any opening blocked; keep free of dust, lint, hair, and anything that may reduce airflow.
12. Keep hair, loose clothing, fingers, and all parts of body away from openings and moving parts, such as the brush bar. Do not point the hose, wand or tools at your eyes or ears or put them in your mouth.
13. Turn off all controls before unplugging.
14. Use extra care when cleaning on stairs. Do not work with the Dyson vacuum above you on the stairs.
15. Do not use to pick up flammable or combustible liquids, such as petrol, or use in areas where they or their vapours may be present.
16. Do not pick up anything that is burning or smoking, such as cigarettes, matches, or hot ashes.
17. Do not use without the clear bin and filter in place.
18. Hold the plug when rewinding onto cable reel. Do not allow the plug to whip when rewinding.
19. The use of an extension cable is not recommended.

SAVE THESE INSTRUCTIONS

THIS VACUUM CLEANER IS INTENDED FOR HOUSEHOLD USE ONLY

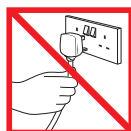

Do not pull on the cable.



Do not store near heat sources.



Do not use near naked flame.



Do not run over the cable.



Do not pick up water or liquids.



Do not pick up burning objects.



Do not use above you on the stairs.



Do not put hands near the brush bar when the vacuum cleaner is in use.

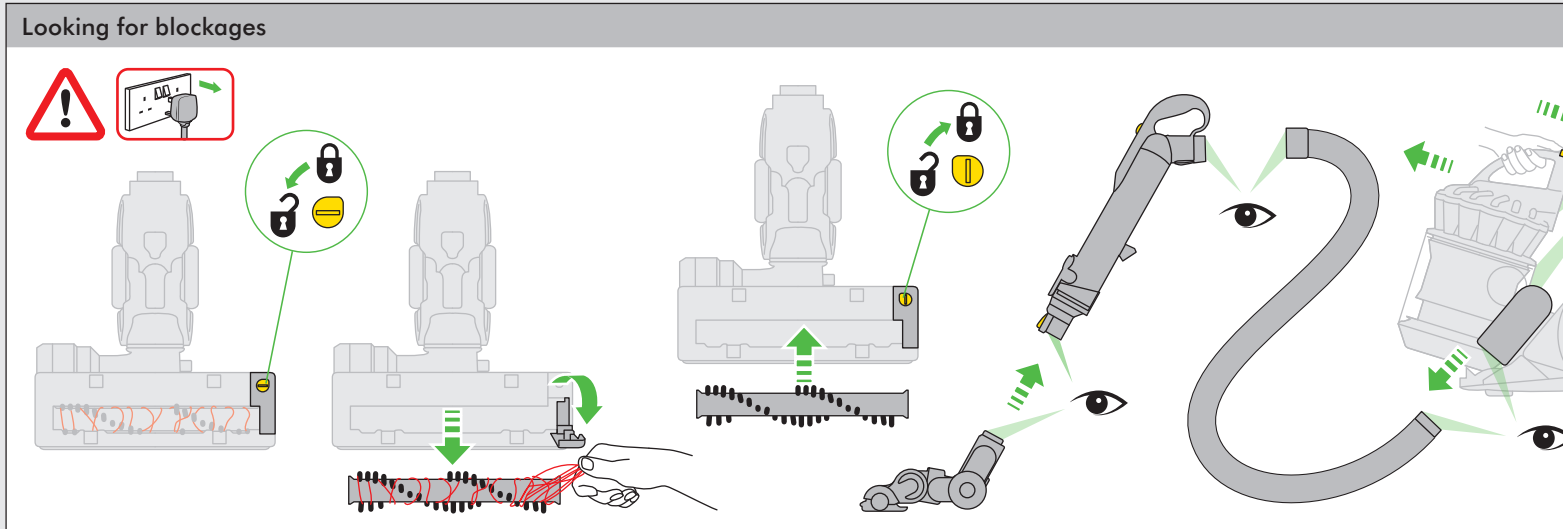
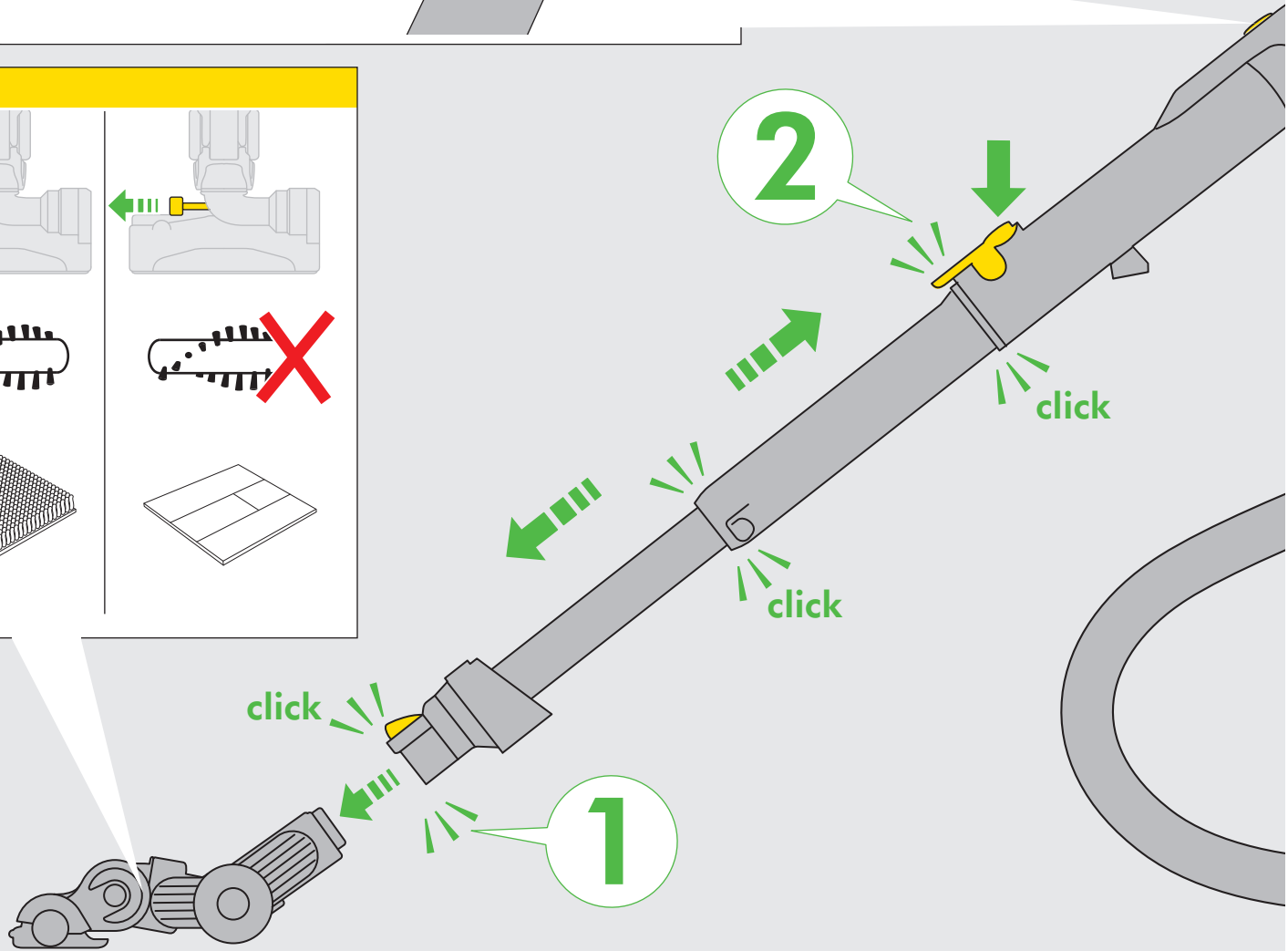
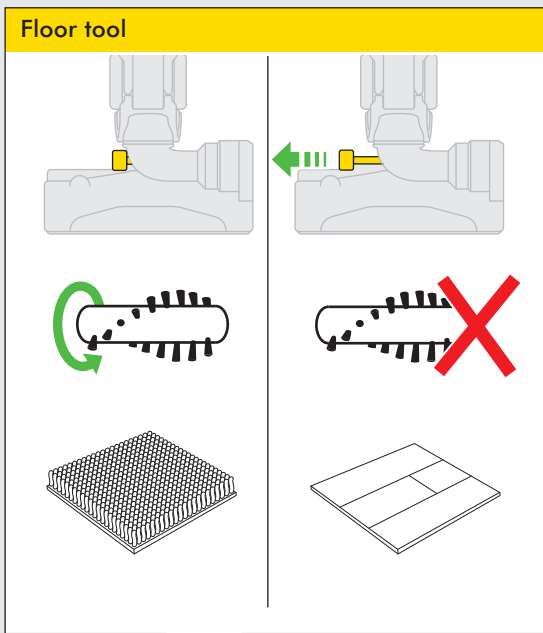
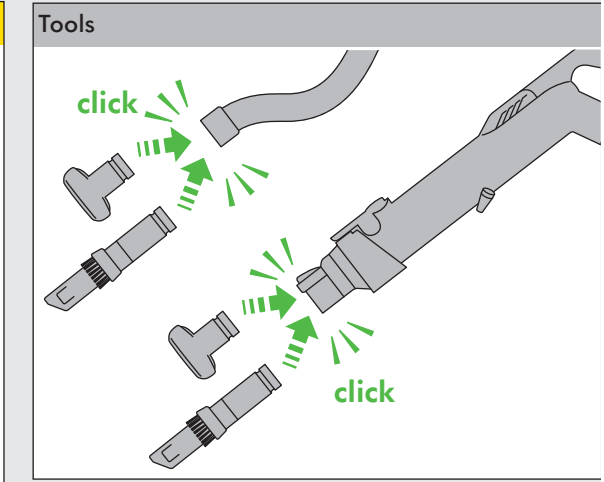
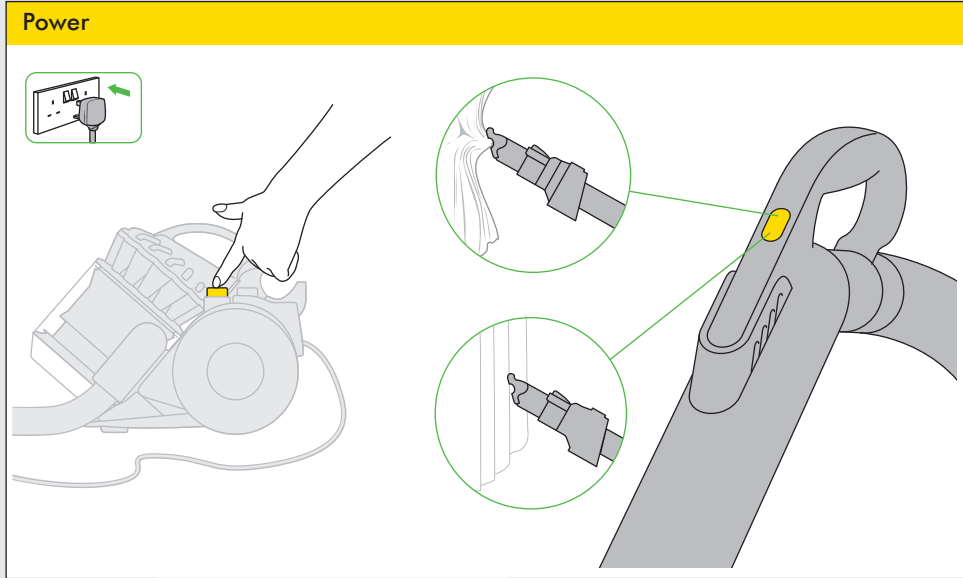

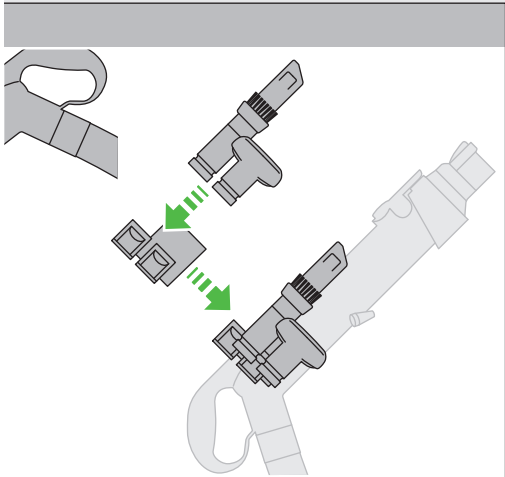

Storage

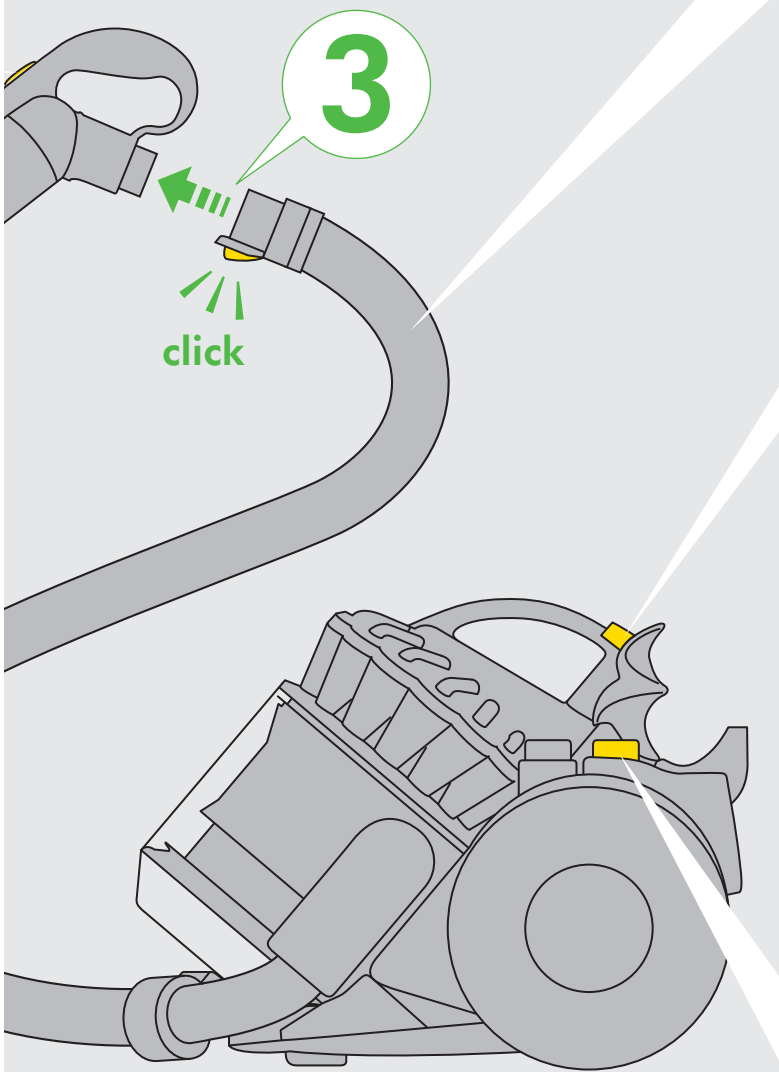
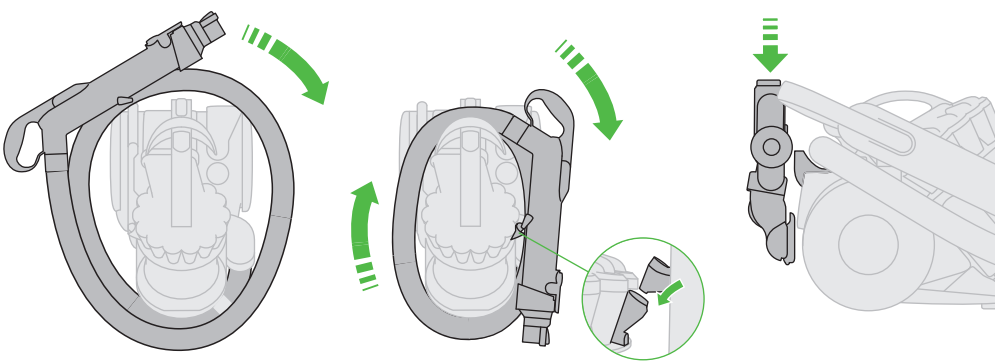

Emptying

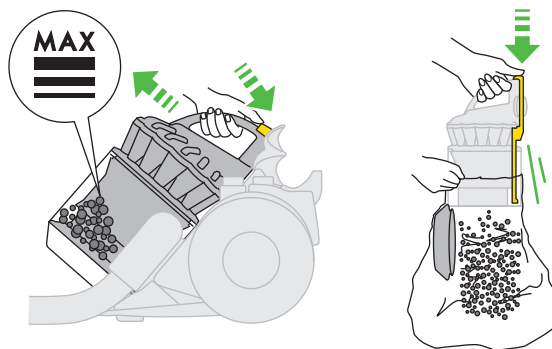
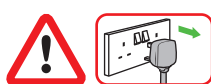

Cleaning

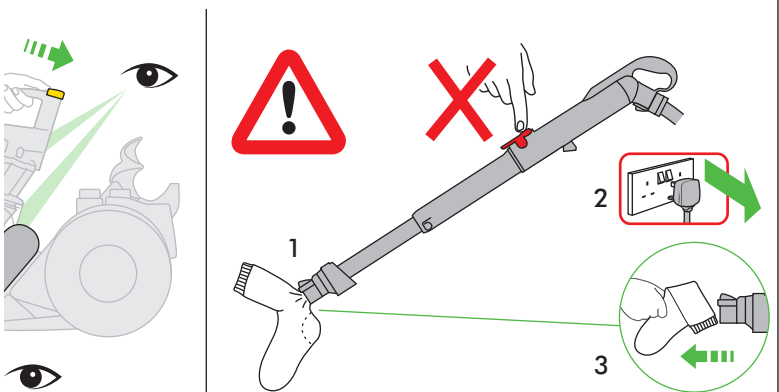
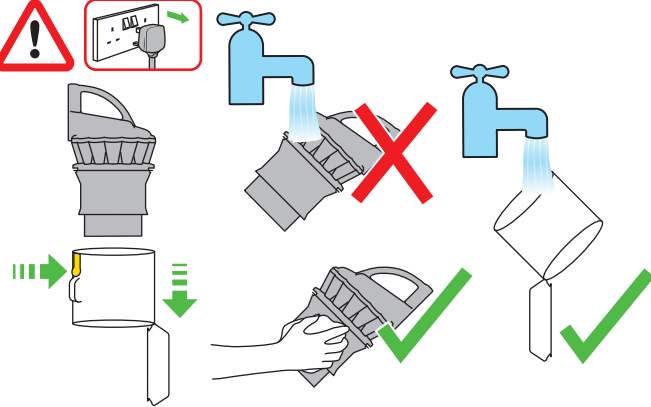

Cable

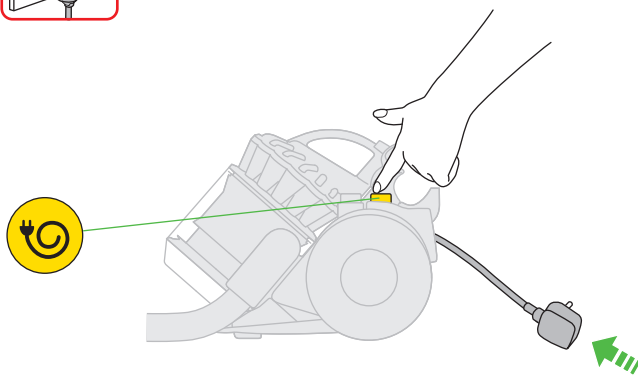

IMPORTANT!

WASH FILTERS

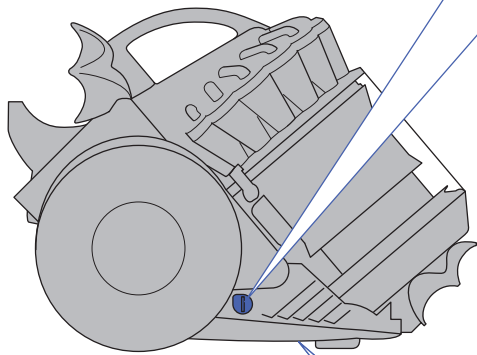

  **Filter A**

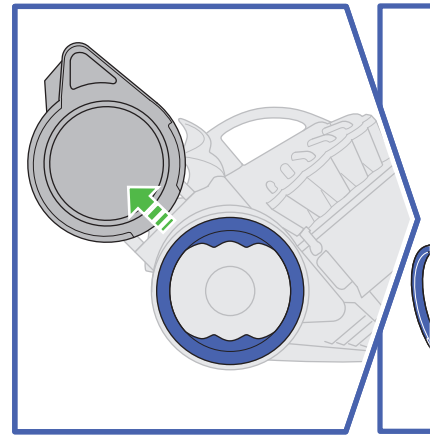
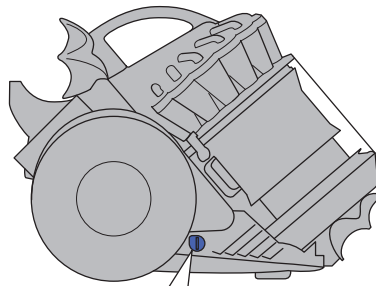

  **Filter B**

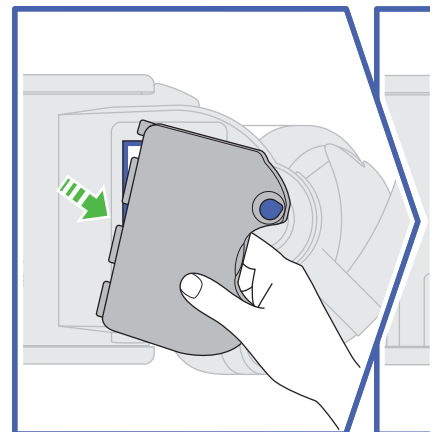
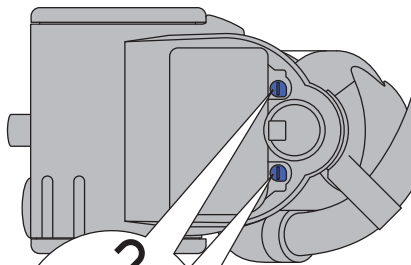

Wash filters with cold water at least every month.

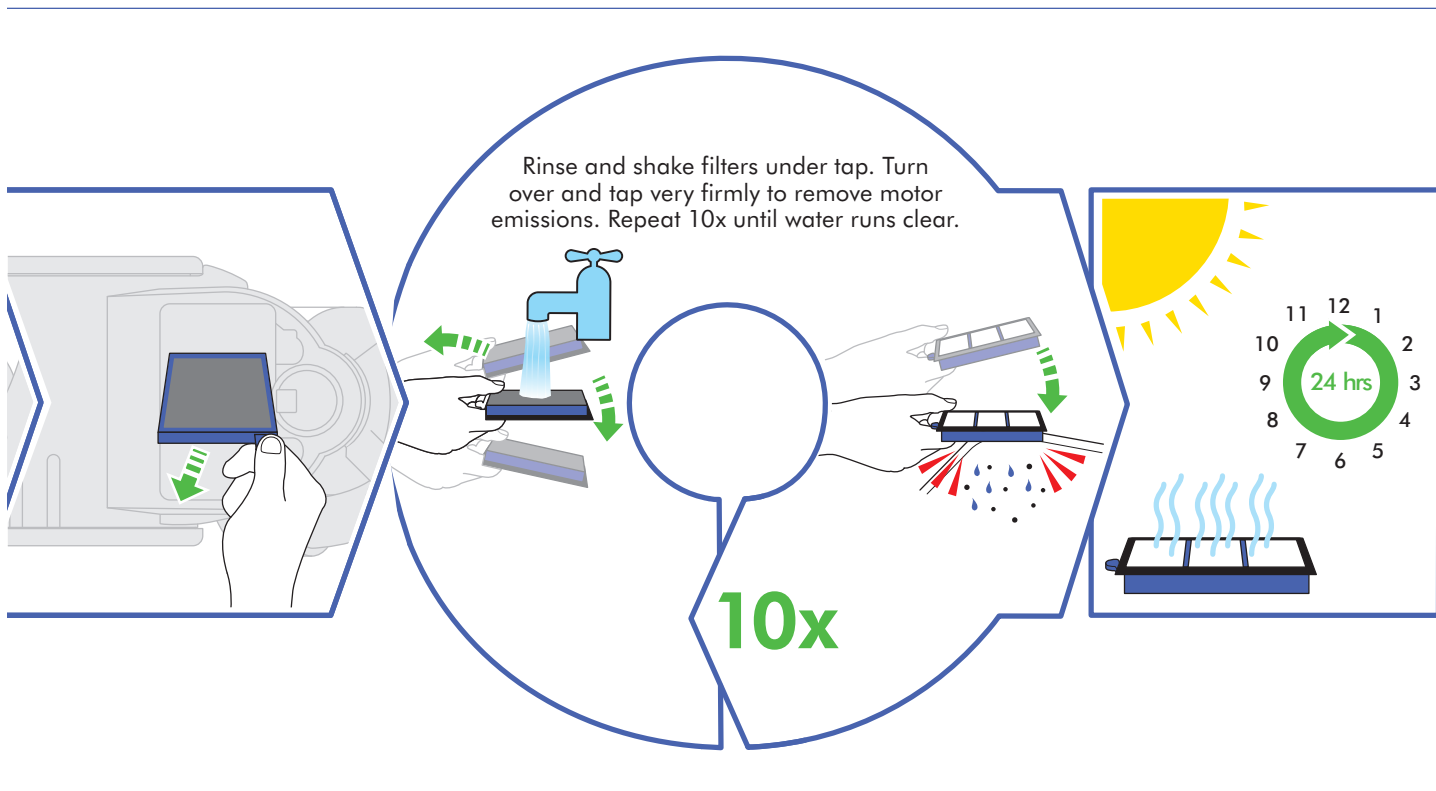
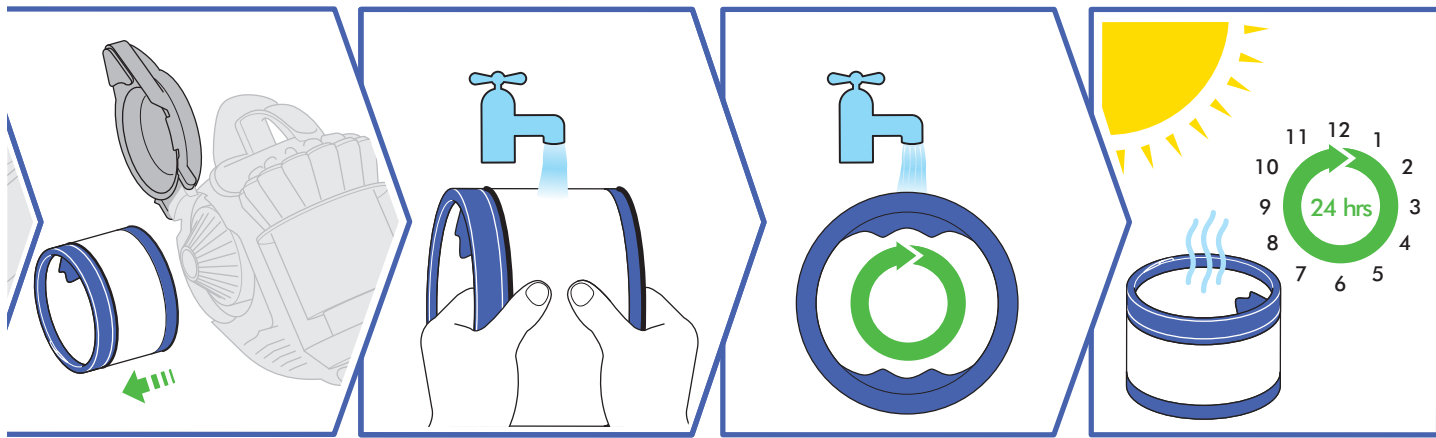

USING YOUR DYSON VACUUM CLEANER

PLEASE NOTE:

- Fine dust such as plaster dust or flour should only be vacuumed in very small amounts.
- Consult your flooring manufacturer's recommended instructions before vacuuming and caring for your floorings, rugs and carpets.
- If used in a garage when car cleaning, care should be taken to wipe the soleplate and wheels with a dry cloth after vacuuming to clean off any sand, dirt or pebbles which could damage delicate floors.
- Store the vacuum cleaner indoors. Do not use or store this vacuum cleaner below 0°C (32°F). Ensure that the vacuum cleaner is at room temperature before operating.

EMPTYING THE CLEAR BIN

CAUTION:

- Switch OFF and unplug the vacuum cleaner before emptying the bin. Empty as soon as the dirt reaches the level of the MAX mark – do not overfill. To remove the clear bin from the machine press the button at the rear of the carrying handle. To release the dirt, press the red bin release button. Emptying into a bag is recommended for allergy sufferers. The British Allergy Foundation has approved this product. It is a UK national charity with the aim of improving awareness, prevention and treatment of allergies.

PLEASE NOTE:

- Do not use the vacuum cleaner without the clear bin in place.
- To minimise dust and allergen contact when emptying, encase the clear bin tightly in a plastic bag and empty. Remove the clear bin carefully and seal bag tightly, dispose as normal.

CLEANING THE CLEAR BIN

CAUTION:

- Do not immerse the whole cyclone in water or pour water into the cyclones.
- Ensure the bin is completely dry before replacing.

PLEASE NOTE:

- Do not use detergents, polishes or air fresheners to clean the bin.
- Do not put the bin in a dishwasher.
- When vacuuming, certain carpets may generate small static charges in the clear bin. These are entirely harmless and not associated with the main supply. To minimise any effect from this, do not put your hand or insert any object into the clear bin unless you have first emptied it and rinsed it out with cold water.
- Clean the shroud with a cloth or dry brush to remove lint and dust.

WASHING YOUR FILTERS

DO THIS EVERY MONTH

CAUTION:

- Switch OFF and unplug the vacuum cleaner before removing the filters.
- Ensure filters are completely dry before refitting into the vacuum cleaner. This machine has two filters, located as shown. It is important to check your filters regularly and wash at least every month according to instructions, to maintain performance. Filter B should be rinsed and tapped out until the water runs clean, then tapped out again to ensure all excess water is removed. This will normally require up to 10 rinse cycles. Please leave to dry completely for 24 hours.

PLEASE NOTE:

- The filters may require more frequent washing if vacuuming fine dust.
- Do not use detergents to clean the filters.
- Do not put the filters in a dishwasher, washing machine, tumble dryer, oven, microwave or near an open flame.

LOOKING FOR BLOCKAGES

CAUTION:

- Switch OFF and unplug the vacuum cleaner before checking for blockages.
- Beware of sharp objects when clearing blockages.
- Refit all parts of the machine securely before using.

PLEASE NOTE:

- Clearing blockages is not covered by your vacuum cleaner's limited guarantee. If any part of your vacuum cleaner becomes blocked, it may overheat and then automatically shut off. Unplug the vacuum cleaner and leave to cool down. Clear blockage before restarting.
- Large items may block the tools or wand inlet, if this happens switch the vacuum cleaner off and remove the plug before removing the blockage. Do not operate the wand release catch.

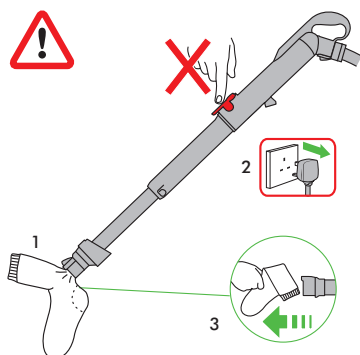

CLEARING BRUSH BAR OBSTRUCTIONS



CAUTION:

- Switch 'OFF' and unplug the vacuum cleaner before clearing brushbar obstructions.
- If your brushbar is obstructed, it may shut off. If this happens you will need to remove brushbar as shown and clear any obstructing debris.

DISPOSAL INFORMATION

This product should not be treated as household waste. Instead it should be handed over to the applicable collection point for the recycling of electrical and electronic equipment – this may be your local civic amenity site or a facility provided by the retailer selling the product or a replacement product. By ensuring this product is disposed of correctly, you will help prevent potential negative consequences for the environment and for human health, which could otherwise be caused by inappropriate waste handling of this product. For more detailed information about recycling of this product, please contact the Dyson Customer Care Helpline, your local authority civic amenity site or the retailer selling the product or a replacement product.

GUARANTEE – TERMS AND CONDITIONS

DYSON CUSTOMER CARE

If you have a question about your Dyson vacuum cleaner, call the Dyson Customer Care Helpline with your serial number and details of where and when you bought the vacuum cleaner, or contact us via the website. The serial number can be found on the main body of the vacuum cleaner behind the clear bin. Most questions can be solved over the phone by one of our Dyson Customer Care Helpline staff.

If your vacuum cleaner needs service, call the Dyson Customer Care Helpline so we can discuss the available options. If your vacuum cleaner is under guarantee, and the repair is covered, it will be repaired at no cost.

PLEASE REGISTER AS A DYSON MACHINE OWNER

THANK YOU FOR CHOOSING TO BUY A DYSON VACUUM CLEANER.

To help us ensure you receive prompt and efficient service, please register as a Dyson machine owner. There are three ways to do this:

- Online at www.dyson.co.uk
- By calling the Dyson Customer Care Helpline.
- By completing and returning the enclosed form to us by mail. This will confirm ownership of your Dyson vacuum cleaner in the event of an insurance loss, and enable us to contact you if necessary.

LIMITED 5 YEAR GUARANTEE

TERMS AND CONDITIONS OF THE DYSON 5 YEAR LIMITED GUARANTEE.

WHAT IS COVERED

- The repair or replacement of your vacuum cleaner (at Dyson's discretion) if your vacuum cleaner is found to be defective due to faulty materials, workmanship or function within 5 years of purchase or delivery (if any part is no longer available or out of manufacture Dyson will replace it with a functional replacement part).
- Use of the vacuum cleaner in UK and Ireland.

WHAT IS NOT COVERED

- Dyson does not guarantee the repair or replacement of a product as a result of:
 - Normal wear and tear (e.g. fuse, belt, brush bar, batteries etc).
 - Accidental damage, faults caused by negligent use or care, misuse, neglect, careless operation or handling of the vacuum cleaner which is not in accordance with the Dyson Operating Manual.
- Blockages – please refer to the Dyson Operating Manual for details of how to unblock your vacuum cleaner.
- Use of the vacuum cleaner for anything other than normal domestic household purposes.
- Use of parts not assembled or installed in accordance with the instructions of Dyson.
- Use of parts and accessories which are not Dyson Genuine Components.
- Faulty installation (except where installed by Dyson).
- Repairs or alterations carried out by parties other than Dyson or its authorised agents.
- If you are in any doubt as to what is covered by your guarantee, please call the Dyson Customer Care Helpline.

SUMMARY OF COVER

- The guarantee becomes effective at the date of purchase (or the date of delivery if this is later).
- You must provide proof of delivery/purchase before any work can be carried out on your vacuum cleaner. Without this proof, any work carried out will be chargeable. Please keep your receipt or delivery note.
- All work will be carried out by Dyson or its authorised agents.
- Any parts which are replaced will become the property of Dyson.
- The repair or replacement of your vacuum cleaner under guarantee will not extend the period of guarantee.
- The guarantee provides benefits which are additional to and do not affect your statutory rights as a consumer.

ABOUT YOUR PRIVACY

Your information will be held by Dyson Limited and its partner companies for promotional, marketing and servicing purposes.

If your personal details change, if you change your mind about any of your marketing preferences or if you have any queries about how we use your information, please let us know by contacting Dyson Limited, Tetbury Hill, Malmesbury, Wiltshire SN16 0RP England, or by calling the Dyson Customer Care Helpline on UK: 0800 298 0298 or IRL: 01 475 7109. Or you can email us at askdyson@dyson.co.uk.

For more information on how we protect your privacy, please see our privacy policy on www.dyson.co.uk

The British Allergy Foundation Seal of Approval is a UK registered trademark of the British Allergy Foundation.

PRODUCT INFORMATION

Product weight 7.2kg.

Please note: Small details may vary from those shown.

This product is protected by the following intellectual rights:

PATENT/PATENT APPLICATION NUMBERS

AU 637272; EP 0636338; JP 1948863; US 5,078,761; AU 697029;
EP 0800360; JP 3449723; US 5,893,936; AU 736843; EP 1087688;
JP 3550360; AU 2001240894; EP 1268076; JP 2003-528704; US 6,835,222;
AU 2002226556; CA 2,439,250; EP 1370172; JP 2004-528876; US 6,991,666;
AU 744408; EP 1361812; JP 2004-537336; US 7,278,181; AU 2003252873;
CA 2,449,304; EP 1380247; JP 2004-100960; US 7,168,128; AU 2002233553;
CA 2,439,247; EP 1365676; JP 2004-524097; US 2004-0078925;
AU 2002225232; CA 2,438,079; EP 1361815; JP 3940082; US 6,974,488;
JP 2007-152136; GB 2407022; JP 2004-023962; AU 2003-255837;
EP 1551270; GB 2392827; JP 2004-023963; US 2006-085943; EP 1576719;
GB 2396491; JP 2006-511186; US 2006-0132081; EP 1542574; EP 1664560;
GB 2406146; JP 2007-506053; US 2007-230839; EP 1680858;
JP 2007-506398; US 2007-0194637; AU 2005243851; CA 2,564,599;
EP 1748848; GB 2413974; JP 2007-508967; US 2007-0175189;
AU 2005244379; CA 2,566,071; EP 1748718; GB 2413941; JP 2007-510099;
US 2007-0226937; AU 2005243454; CA 2,566,406; EP 1748719;
GB 2413942; JP 2007-512311; US 11/596,174; US 11/794,227; GB 2426726;
WO 2006/125945; GB 2426473; WO 2006/125946.

Designs/Design applications

AU 301268; ED 217666-0001; GB 3016553; JP 1228173; US D518933;
AU 301393; ED 241930-0001; GB 3017293; JP 1236657; US D526102;
AU 301396; ED 241930-0002; GB 3017294; JP 1236658; US D537219;
AU 301394; ED 241930-0003; GB 3017295; JP 1236659; US D519,696;
AU 314889; GB 4000251; JP 1311067; ED 701701-0001.

Equivalent patents, registered designs and applications exist in other countries.

IMPORTANT!

WASH FILTERS



Wash filters with cold water at least every month.



Dyson Customer Care

If you have a question about your Dyson vacuum cleaner, call the Dyson Customer Care Helpline with your serial number and details of where and when you bought the cleaner, or contact us via the Dyson website. The serial number can be found on the main body of the vacuum cleaner behind the clear bin.

UK Dyson Customer Care
askdyson@dyson.co.uk
0800 298 0298

Dyson Ltd, Tetbury Hill, Malmesbury, Wiltshire SN16 0RP.

IRL Dyson Customer Care
irelandservice@dyson.com
01 475 7109

Dyson Ireland Limited, Unit G10, Grants Lane,
Greenogue Business Park, Rathcoole, Dublin 24



